

Example of accessory choice:  
Red line indicates ridge of track

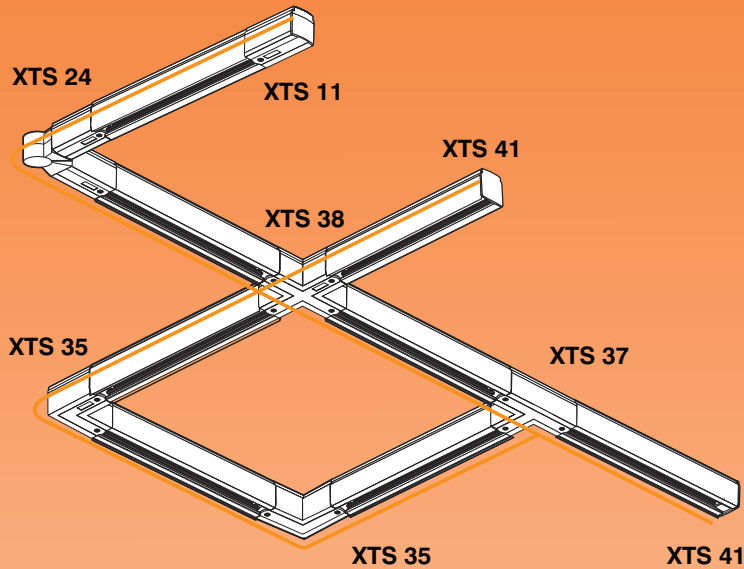

### Use of L- and T-connectors

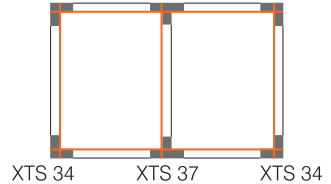
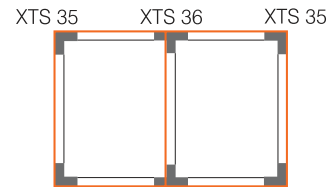
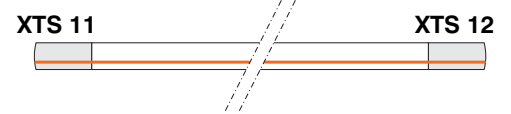

Floor view

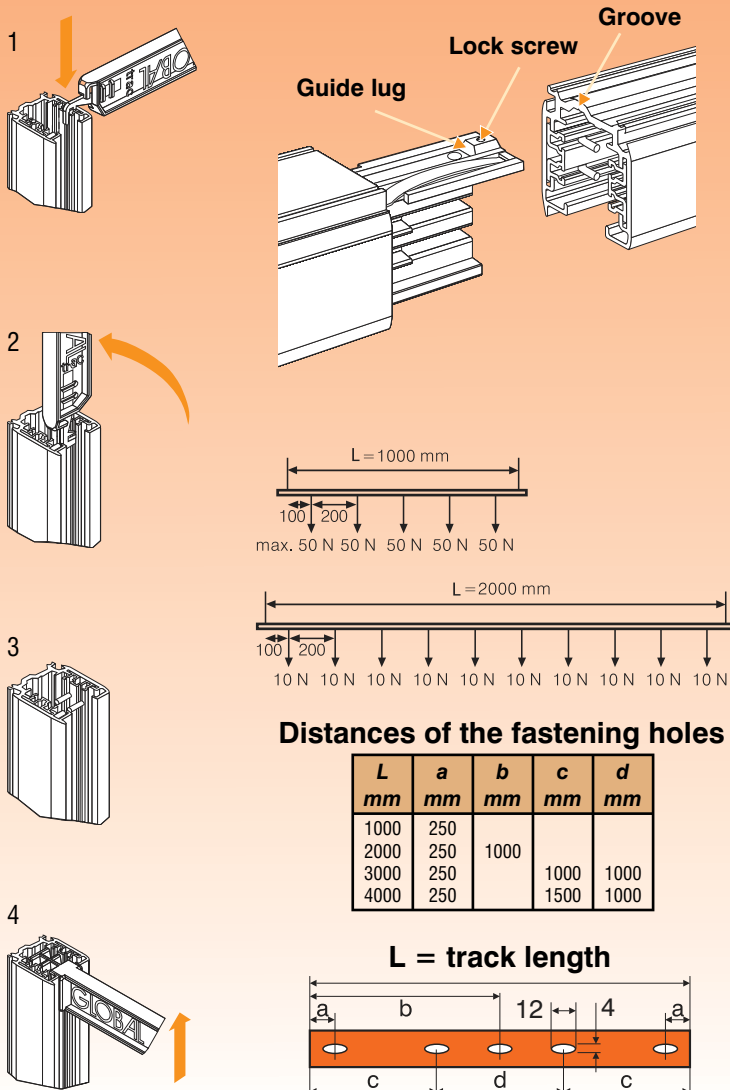

Distances of the fastening holes

| L<br>mm | a<br>mm | b<br>mm | c<br>mm | d<br>mm |
|---------|---------|---------|---------|---------|
| 1000    | 250     | 1000    | 1000    | 1000    |
| 2000    | 250     |         |         |         |
| 3000    | 250     |         | 1000    | 1000    |
| 4000    | 250     |         | 1500    | 1000    |

L = track length

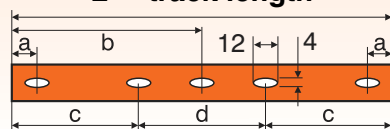

### Installation

#### Installation of the connector parts

When installing the connector parts to the **GLOBAL pro** track, it is necessary to ensure that the guide lug enters the groove in the base of the track. The fastening of the connectors to the track is secured by the lock screws.

#### How to cut the GLOBAL pro

**GLOBAL pro** lighting tracks are supplied in standard lengths. They are also easy to cut to the required length with a hacksaw or with a circular saw designed for aluminium cutting. After the **GLOBAL pro** track has been cut, the conductors have to be bent at an angle of 90 degrees. Use the bending tool XTSV 12 for bending. The conductors can be measured and finished with the plastic gauge at the other end of the tool. The bent conductors are at the right distance from the end of the track when the plastic gauge does not protrude but lies flush with the track end.

#### The fastening distance and the loading capacity

The tracks are supplied complete with punched fastening holes (see the table). The recommended fastening distance is

L = 1000 mm.

NOTE: A load not heavier than 10 kg may hang on a power takeoff adapter, the pull strength being 100 N (1 kp = 9.81 N) and the maximum torque 2.5Nm.

(XTSA 66 and GA69 5 kg / 50 N).